



HOLDING & DISPLAY CABINETS



*Fresh merchandising ideas for daytime, nighttime
and all of the snack times in between.*





Model FSD-2



Model FSDT-2X with accessory 5-shelf angle rack, decals, and sign holder (sign not included)

FSD

FLAV-R-SAVOR® HUMIDIFIED DISPLAY CABINETS

Choose display cabinets that will work harder for you around the clock. Choose Flav-R-Savor® from Hatco.

Balancing the right combination of heat and humidity, the rugged Flav-R-Savor humidified cabinet keeps food fresh and safe for up to four hours, reducing waste and maintaining the high quality you need to satisfy your customers.

Plus, with a complete range of sizes, door options and rack types, you can select the cabinet that will let you sell more whether it's breakfast, lunch or dinner.

- Keep food hot and fresh at safe temperatures
- Internal fluorescent lighting helps showcase product
- Full cabinet display with tempered glass doors and side panels retains maximum heat
- Heat is diffused throughout cabinet providing gentle, even heat
- Continuous humidity keeps food fresher
- Two-door models offer pass-through convenience

FSDT

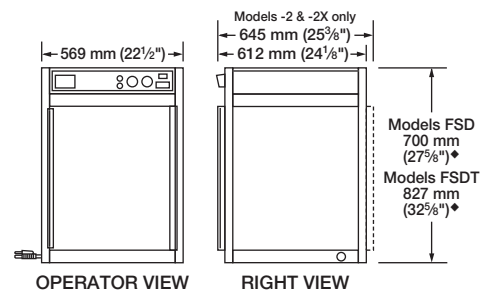

DIMENSIONS

Cabinet Openings: FSD – 483 W x 473 H mm (19" x 18 5/8").
 FSDT – 483 W x 603 H mm (19" x 23 3/4").

♦ Add 25 mm (1") to height for display sign.

Choose a *Designer Color* to match any décor.



Printed colors are a representation and may not exactly match our *Designer* colors. Non-standard colors are non-returnable.

FOOD GRAPHIC DECALS (Adhesive)

Pizza, Chicken, Pretzel, Croissant/Biscuit



MERCHANDISING DISPLAY SIGNS (Requires Sign Holder)



**HUMIDIFIED
HOLDING & DISPLAY
CABINETS**

CONTROLLED MOISTURIZED HEAT KEEPS HOT FOODS FRESH LONGER

The Hatco "operator friendly" control panel makes it easy to set the correct heat and humidity levels. Just fill up the water reservoir with the convenient front-fill cup, then set the humidity to the desired level and the air temperature to the desired temperature (temperature range is 27°-91°C (80°-195°F)). "LO H2O" flashes on the digital display when the water reservoir is low. A Mechanical Thermostat Control with individual dials for temperature and humidity is a factory installed option in lieu of electronic controls.

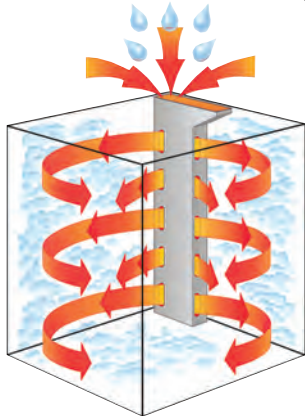
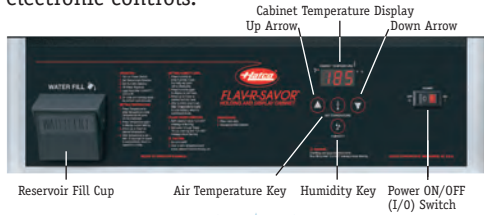

Model FSD-2X with 3-tier pan rack, accessory decals and food pans



Model FSDT-1 with rotating rack motor, 4-tier circle rack, optional *Designer* color, accessory decals and food pans

SPECIFICATIONS

Standard Models

Model*	Type	Rack Style†	Shipping Weight
FSD-1	1 Door	3-Tier Circle Rack w/Motor	51 kg (113 lbs.)
FSD-1X	1 Door	3-Tier Pan Rack w/o Motor	50 kg (111 lbs.)
FSD-2	2 Doors	3-Tier Circle Rack w/Motor	52 kg (114 lbs.)
FSD-2X	2 Doors	3-Tier Pan Rack w/o Motor	51 kg (112 lbs.)

Tall Models

Model*	Type	Rack Style†	Shipping Weight
FSDT-1	1 Door	4-Tier Circle Rack w/Motor	54 kg (120 lbs.)
FSDT-1X	1 Door	4-Tier Pan Rack w/o Motor	54 kg (118 lbs.)
FSDT-2	2 Doors	4-Tier Circle Rack w/Motor	55 kg (122 lbs.)
FSDT-2X	2 Doors	4-Tier Pan Rack w/o Motor	54 kg (120 lbs.)

* Models FSD-1, FSD-2, FSDT-1 and FSDT-2 include rack motor. Models with "X" designator do not have revolving display and are NOT available for retrofit.

† Rack listed is included with unit. Optional racks available, see Display Rack Selection.

VOLTAGE

220 volts, 50 Hz, 1440 watts, 6.5 amps (CEE 7/7 Schuko).

240 volts, 50 Hz, 1440 watts, 6.0 amps (BS-1363 British).

120 volts, 60 Hz, 1440 watts, 12 amps (NEMA 5-15P).

CORD LOCATION

Facing controls, left-hand side panel, lower right corner.

WATER TANK CAPACITY

3 liters (¾ gallon).

WATER QUALITY REQUIREMENTS

See page 12 of this brochure for details.

DISPLAY RACK SELECTIONS

(Racks shown are for FSD models only)

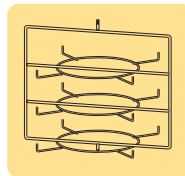

3-Tier Circle Rack ▲
(Max. 483 mm Dia. (19") Pans)
(Rack Opening 117 mm (4⁵/₈")

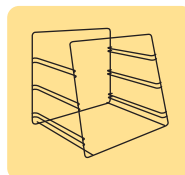

3-Tier Pan Rack
(Max. 457 x 330 mm (18" x 13")
Half-Size Sheet Pans)
(Rack Opening 89 mm (3¹/₂")

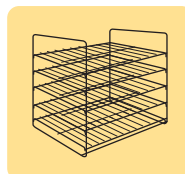

5-Shelf Multi-Purpose Rack
(Max. 457 x 330 mm (18" x 13")
Half-Size Sheet Pans)
(Rack Opening 64 mm (2¹/₂")

DISPLAY RACK SELECTIONS

(Racks shown are for FSDT models only)

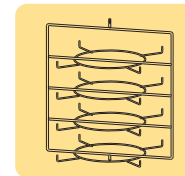

4-Tier Circle Rack ▲
(Max. 483 mm Dia. (19") Pans)
(Rack Opening 117 mm (4⁵/₈")

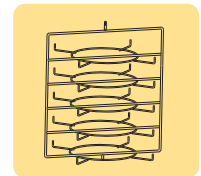

5-Tier Circle Rack ▲
(Max. 483 mm Dia. (19") Pans)
(Rack Opening 98 mm (3⁷/₈")

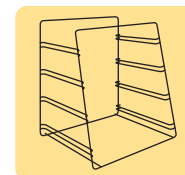

4-Tier Pan Rack
(Max. 457 x 330 mm (18" x 13")
Half-Size Sheet Pans)
(Rack Opening 89 mm (3¹/₂")

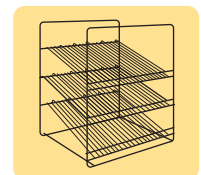

3-Shelf Angle Rack
(Rack Opening 89 mm (3¹/₂")

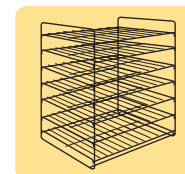

7-Shelf Multi-Purpose Rack
(Max. 457 x 330 mm (18" x 13")
Half-Size Sheet Pans)
(Rack Opening 64 mm (2¹/₂")

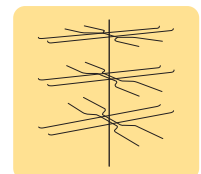

3-Tier Pretzel Tree ▲
(Rack Opening 149 mm (5⁷/₈")

▲ Requires motorless rack coupling on -X Models

COUNTERTOP

HUMIDIFIED HOLDING & DISPLAY CABINETS

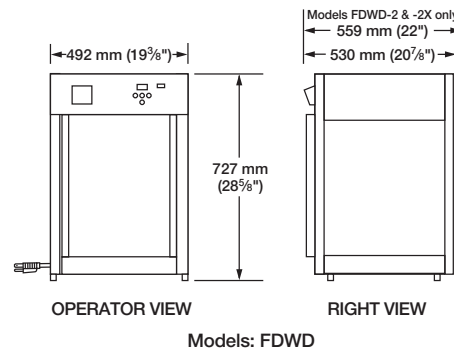
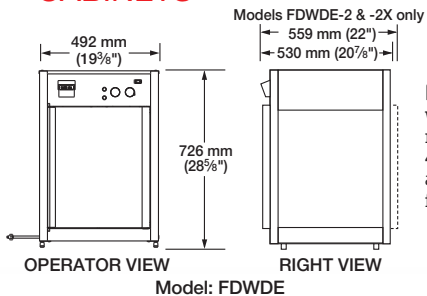

FDWDE

FLAV-R-FRESH® HUMIDIFIED DISPLAY CABINETS

It's time to make a maximum impact on your bottom line using a minimum of counterspace. The compact Flav-R-Fresh® line gives you a profitable way to increase your impulse-buy sales.

- Controlled heat and humidity keeps crisp foods crisp and moist foods moist for hours
- Large single door models provide fast access to food racks
- Reversible two-door models offer pass-through convenience
- A variety of racks add flexibility and merchandising appeal
- Ideal for restaurants, pizzerias, convenience stores, concession stands, snack bars and kiosks

FDWD



Model FDWD-2X with standard 4-shelf multi-purpose rack

DISPLAY RACK SELECTIONS

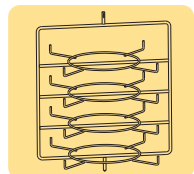

4-Tier Circle Rack ▲
(Max. 381 mm Dia. (15") Pans)
(Rack Opening 83 mm (3¹/₄")

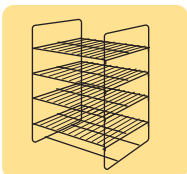

4-Shelf Multi-Purpose Rack
(Max. 457 x 330 mm (18" x 13")
Half-Size Sheet Pans)
(Rack Opening 95 mm (3³/₄")

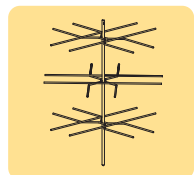

3-Tier Pretzel Tree ▲
(Rack Opening 149 mm (5⁷/₈")

▲ Requires motorless rack coupling on -X Models

Choose a *Designer Color* to match any décor.

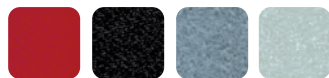

Warm Red Black Gray Granite White Granite



Navy Blue Hunter Green Antique Copper

Printed colors are a representation and may not exactly match our *Designer* colors. Non-standard colors are non-returnable.

DIMENSIONS

Cabinet Opening: 400 W x 502 H mm (15³/₄" x 19³/₄".)

SPECIFICATIONS

Model*	Type	Rack Style	Shipping Weight
FDWDE-1	1 Door	4-Tier Circle Rack† w/Motor	38 kg (84 lbs.)
FDWDE-1X	1 Door	4-Shelf Multi-Purpose Rack w/o Motor	38 kg (84 lbs.)
FDWDE-2	2 Doors	4-Tier Circle Rack† w/Motor	38 kg (84 lbs.)
FDWDE-2X*	2 Doors	4-Shelf Multi-Purpose Rack w/o Motor	38 kg (84 lbs.)

Model*	Type	Rack Style	Shipping Weight
FDWD-1	1 Door	4-Tier Circle Rack† w/Motor	41 kg (90 lbs.)
FDWD-1X	1 Door	4-Shelf Multi-Purpose Rack w/o Motor	41 kg (90 lbs.)
FDWD-2	2 Doors	4-Tier Circle Rack† w/Motor	41 kg (90 lbs.)
FDWD-2X*	2 Doors	4-Shelf Multi-Purpose Rack w/o Motor	41 kg (90 lbs.)

* Models FDWDE-1, FDWD-1, FDWDE-2 and FDWD-2 include rack motor. Models with "X" designator do not have revolving display and are NOT available for retrofit.

† Pretzel Rack available as substitute for Circle Rack.

• Accommodates half-size sheet pans.

FOOD AND GRAPHIC DECALS (Adhesive)

Pizza, Hot Pizza, Hot Pretzels



COUNTERTOP

NON-HUMIDIFIED HOLDING & DISPLAY CABINETS



Magnetically adjustable shelves provide flexibility for a variety of product choices



Model MDW-1X
In *Designer* black with optional hood with backlit sign cutout on one side (sign included)

MINI DISPLAY WARMER NON-HUMIDIFIED DISPLAY CABINETS

Warm cookies. Hot sandwiches. Soft pretzels. Make anytime the right time for these types of items. This non-humidified, compact model keeps them hot and ready for your customers to grab-and-go.

- Merchandising flexibility thanks to magnetically adjustable shelves that allow for slant or horizontal display providing maximum visibility
- Single-door or pass-through models available for server and self-serve operations
- Perfect for locations with limited counterspace

MDW

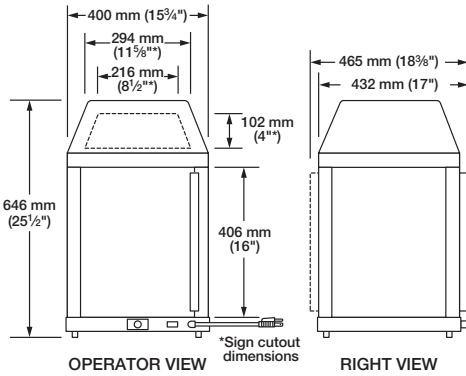

DIMENSIONS

Cabinet Opening: 315 W x 396 H mm (12 1/2" x 15 5/8").
 Trapezoid Shape Sign Holder: 216 W mm at top x 102 H x 294 W mm at bottom (8 1/2" x 4" x 11 5/8").

SPECIFICATIONS

Model	Type	Rack Style	Shipping Weight
MDW-1X	1 Doors	3-Shelf Adjustable	21 kg (47 lbs.)
MDW-2X	2 Doors	3-Shelf Adjustable	23 kg (50 lbs.)

VOLTAGE

230 volts, 50 Hz, 510 watts, 2.2 amps (CEE 7/7 Schuko, BS-1363 British).

120 volts, 60 Hz, 470 watts, 3.9 amps (NEMA 5-15P).

CORD LOCATION

Facing controls, lower right corner.

DESIGNER COLOR OPTIONS

See page 4 to choose the *Designer* color that best matches your décor.

Model MDW-1X with standard *Designer* color and optional hood with backlit sign cutout on one side (sign included)



SPECIALTY COUNTERTOP

HUMIDIFIED HOLDING & DISPLAY CABINETS

Model WFST-2X with 4-shelf multi-purpose rack, optional *Designer* color, self-closing sliding doors and accessory food pans



Choose a *Designer* Color to match any décor.



Printed colors are a representation and may not exactly match our *Designer* colors. Non-standard colors are non-returnable.

WFST

FLAV-R-SAVOR® HUMIDIFIED LARGE CAPACITY DISPLAY CABINETS

Expecting peak crowds at meal time? Turn to the larger capacity Flav-R-Savor® Wide Display Cabinet. Place hot product straight from the oven directly into the full-view cabinets and increase your impulse sales.

- Holds standard 457 x 660 mm (18" x 26") sheet pans for efficient kitchen operation
- Multipurpose display rack included
- Optional self-closing sliding doors for self-serve applications
- Stacking kit available to maximize floor space and double display capacity



FOOD AND GRAPHIC DECALS (Adhesive)

Chicken, Ribs, Today's Hot Specials



Today's Hot Specials

DIMENSIONS

Cabinet Opening: 711 W x 556 H mm (28" x 21 7/8").

SPECIFICATIONS

Model	Type	Rack Style	Shipping Weight
WFST-1X	2 Doors	4-Shelf Stationary	83 kg (182 lbs.)
WFST-2X	4 Doors	4-Shelf Stationary	85 kg (188 lbs.)

VOLTAGE

220 volts, 50 Hz, 1750 watts, 8.0 amps (CEE 7/7 Schuko).

240 volts, 50 Hz, 1790 watts, 7.5 amps (BS-1363 British).

120/208 or 120/240 volts, 60 Hz, 2390 watts, 12.3 amps (NEMA L14-20P).

120 volts, 60 Hz, 1790 watts, 14.9 amps (NEMA 5-15P, NEMA 5-20P – Canada).

CORD LOCATION

Facing controls, left-hand side panel, lower right corner.

WATER TANK CAPACITY

3 liters (3/4 gallon).

WATER QUALITY REQUIREMENTS

See page 12 of this brochure for details.



Model WFST-1X with 4-shelf multi-purpose rack, accessory decals and pans

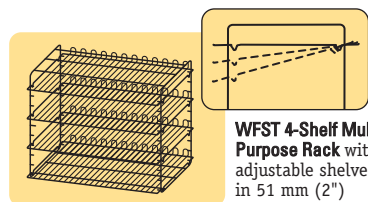
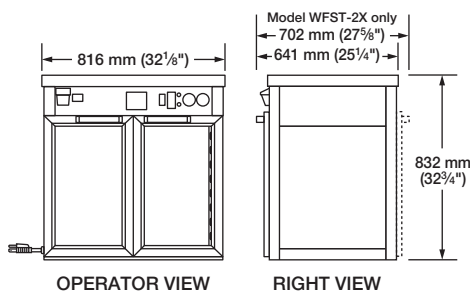

Model WFST-1X operator side

PORTABLE

NON-HUMIDIFIED
HOLDING & DISPLAY
CABINETS

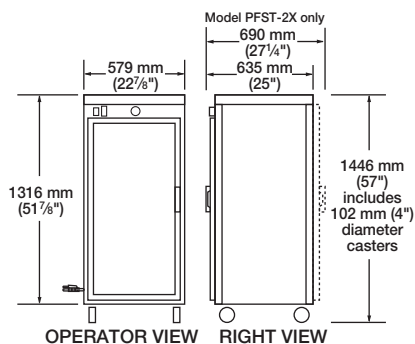

Model PFST-2X
with 8-shelf rack

PFST

FLAV-R-SAVOR® TALL NON-HUMIDIFIED HOLDING CABINETS

It's a great time to build your sales volume with the Flav-R-Savor® Non-Humidified Tall Holding Cabinet. With capacity for up to 16 boxed or eight bagged pizzas, you'll have the tools in place to give your customers hot and fresh carryout and delivery pizza.

- Excellent visibility to assure proper delivery rotation
- Illuminated cabinet interior for easy viewing
- Returns to temperature quickly after opening doors to keep pizza hot



DIMENSIONS

Cabinet Opening: 476 W x 1026 H mm (18³/₄" x 40³/₈"").
Available Shelf Space: 454 W x 454 D mm (17⁷/₈" x 17⁷/₈"").
Rack Opening: 118 H mm (4⁵/₈"").

SPECIFICATIONS

Model	Type	Shipping Weight
PFST-1X	1 Door	81 kg (178 lbs.)
PFST-2X	2 Doors	81 kg (178 lbs.)

VOLTAGE

220 volts, 50 Hz, 1747 watts, 7.9 amps
(CEE 7/7 Schuko).

240 volts, 50 Hz, 1767 watts, 7.4 amps
(BS-1363 British).

120 volts, 60 Hz, 1767 watts, 14.7 amps
(NEMA 5-15P, NEMA 5-20P – Canada).

CORD LOCATION

Facing controls, left-hand side panel,
lower right corner.



SPECIALTY COUNTERTOP

NON-HUMIDIFIED HOLDING & DISPLAY CABINETS

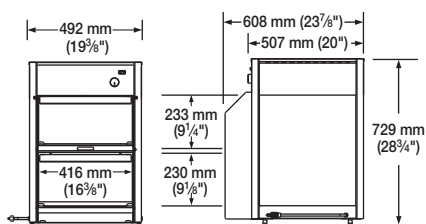

OPERATOR VIEW RIGHT VIEW
Model FDWD-1-MN



Model FDWD-1-MN

MN

MACHO NACHO® CHIP WARMERS

When it's time for a snack, Macho Nacho® is always ready. Keep your chips hot, crisp and tasty with this specialty warmer and display unit. The unique two-door design allows for first-in, first-out chip delivery. And since Macho Nacho circulates air to prevent the loss of natural oils, you will not need to replace stale chips.

- Hold 11 or 18 kg (25 or 40 lbs.) of chips in a very small footprint, reducing refill time
- Two-door access permits easy loading and serving
- Special ductwork forces heat through chips from the bottom up, providing efficient heating

DIMENSIONS

FDWD-1-MN Cabinet Openings:

Upper Door 416 W x 233 H mm (16 3/8" x 9 1/4").
Lower Door 416 W x 230 H mm (16 3/8" x 9 1/8").

FST-1-MN Cabinet Openings:

Upper Door 474 W x 285 H mm (18 5/8" x 11 1/4").
Lower Door 474 W x 252 H mm (18 5/8" x 9 7/8").

SPECIFICATIONS

Model	Type	Shipping Weight
FDWD-1-MN	2 Doors	45 kg (99 lbs.)
FST-1-MN	2 Doors	60 kg (132 lbs.)

VOLTAGE

FDWD-1-MN: 220 volts, 50 Hz, 950 watts, 4.3 amps (CEE 7/7 Schuko).

240 volts, 50 Hz, 1129 watts, 4.7 amps (BS-1363 British).

120 volts, 60 Hz, 1080 watts, 9.0 amps (NEMA 5-15P).

FST-1-MN: 220 volts, 50 Hz, 1219 watts, 5.6 amps (CEE 7/7 Schuko).

240 volts, 50 Hz, 1252 watts, 5.2 amps (BS-1363 British).

120 volts, 60 Hz, 1245 watts, 10.4 amps (NEMA 5-15P).

CORD LOCATION

Facing controls, left-hand side panel, lower right corner.

PRODUCT CAPACITY

FDW-1-MN: 11 kg (25 lbs.).

FST-1-MN: 18 kg (40 lbs.).

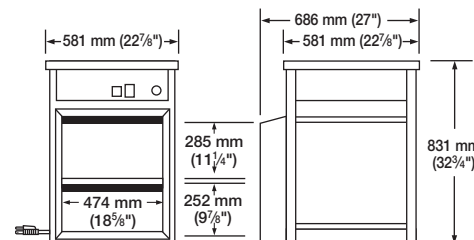

OPERATOR VIEW RIGHT VIEW
Model FST-1-MN



Model FST-1-MN shown in standard bronze



SPECIALTY COUNTERTOP

HEATED AIR CURTAIN CABINETS



Model FSHACH-2
with accessory pans

FLAV-R-SAVOR® HUMIDIFIED & NON-HUMIDIFIED HEATED AIR CURTAIN CABINETS

Deliver exactly what your clientele hungers for anytime of the day. The patented Flav-R-Savor® Heated Air Curtain Cabinets give you immediate access to food with no doors to slow you down during your daily rush. Peak rush times can challenge your operation – Hatco helps you meet this demand with ease.

- A “curtain” of heated air is created by warm air being forced downward through ducts above the opening and then drawn towards the back of the unit
- Perfect for wrapped product and product on sheet pans
- Available in sizes to accommodate half-size or full-size sheet pans
- Available in both humidified and non-humidified to match your product offering

FSHAC FSHACH

FS2HAC PASS-THROUGH

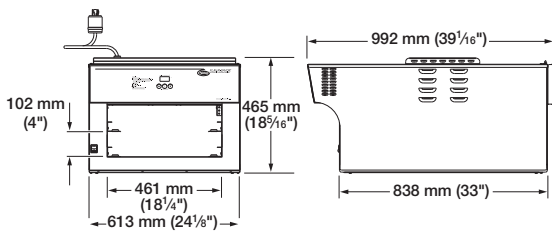

OPERATOR VIEW RIGHT VIEW

Model: FS2HAC-2PT

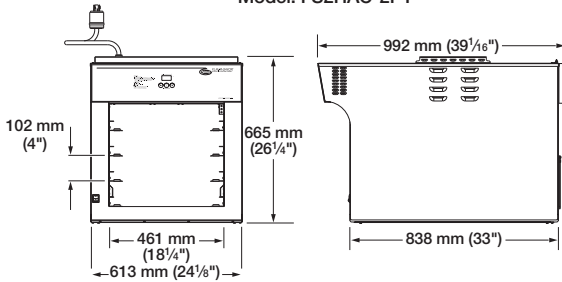

OPERATOR VIEW RIGHT VIEW

Model: FS2HAC-4PT

DIMENSIONS

Cabinet Opening

FSHAC-2, FSHACH-2: 464 W x 232 H mm (18 1/4" x 9 1/8").

FSHACH-3: 464 W x 460 H mm (18 1/4" x 18 1/8").

FS2HAC-2PT: 461 W x 206 H mm (18 1/4" x 8 1/8").

FS2HAC-2PT: 461 W x 410 H mm (18 1/4" x 16 1/8").

SPECIFICATIONS

Model	Type	Shipping Weight
FSHAC-2	2-Tier	45 kg (100 lbs.)
FSHACH-2	2-Tier Humidified	45 kg (100 lbs.)
FSHAC-3	3-Tier	52 kg (115 lbs.)
FS2HAC-2PT	2-Tier Pass-Through	75 kg (165 lbs.)
FS2HAC-4PT	4-Tier Pass-Through	86 kg (190 lbs.)

VOLTAGE

FSHAC-2, -3:

220 volts, 50/60 Hz, 1750 watts, 8.0 amps (CEE 7/7 Schuko).

240 volts, 50/60 Hz, 1750 watts, 7.3 amps (BS-1363 British).

120/208 volts, 60 Hz, 1877 watts, 9.0 amps (NEMA L14-20P).

120 volts, 60 Hz, 1850 watts, 15.4 amps (NEMA 5-20P).

FSHACH-2:

120/208 volts, 60 Hz, 2950 watts, 14.2 amps (NEMA L14-20P).

FS2HAC-2PT:

220 volts, 50/60 Hz, 2538 watts, 11.5 amps (CEE 7/7 Schuko).

240 volts, 50/60 Hz, 3022 watts, 12.6 amps (BS-1363 British).

120/208 or 120/240 volts, 60 Hz, 2589 watts, 10.8 amps

(NEMA L14-20P).

FS2HAC-4PT:

220 volts, 50/60 Hz, 3338 watts, 15.2 amps (CEE 7/7 Schuko).

240 volts, 50/60 Hz, 3362 watts, 14.0 amps (BS-1363 British).

120/208 or 120/240 volts, 60 Hz, 3389 watts, 14.2 amps

(NEMA L14-20P).

CORD LOCATION

FSHAC-2, -3, FSHACH-2: Top of unit towards the back, middle.

FS2HAC-2PT, -4PT: Top of unit towards the back, left side.

WATER TANK CAPACITY (Humidified Models)

FSHACH-2: 9 liters (2 1/4 gallons).

WATER QUALITY REQUIREMENTS

See page 12 of this brochure for details.



Removable
Slant Rack



Removable
Rib Rack



Model FS2HAC-2PT
Pass-Through with accessory pans



Model FS2HAC-4PT
Pass-Through with accessory pans

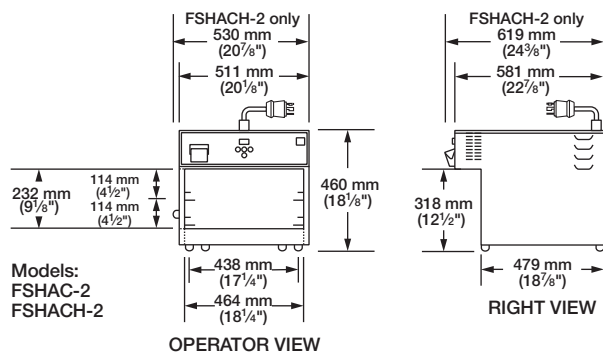

Models:
FSHAC-2
FSHACH-2

OPERATOR VIEW

RIGHT VIEW

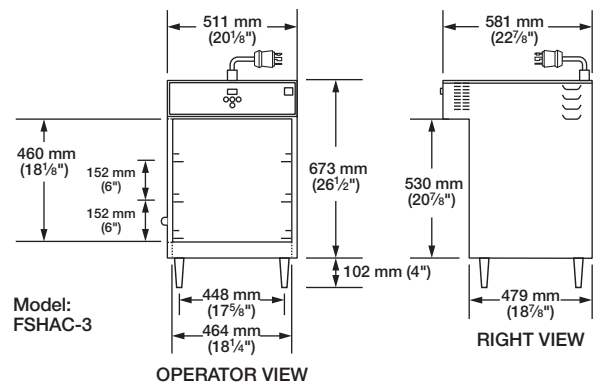

Model:
FSHAC-3

OPERATOR VIEW

RIGHT VIEW

PORTABLE

HUMIDIFIED HOLDING & DISPLAY CABINETS

Model FSHC-7-1 with standard 102 mm (4") casters, tray slides and accessory food pans



FSHC-7

FLAV-R-SAVOR® LOW PROFILE & PORTABLE HUMIDIFIED HOLDING CABINETS

When it's time for flexibility, turn to Hatco portable cabinets. You'll find the fit that's right for you with the Flav-R-Savor® Low Profile or standard Portable Holding Cabinets. The low profile model is perfect for under work counters and both models are easy to move and maneuver when necessary.

FSHC-6

- Accommodates full sheet pans or Gastronorm pans
- Insulated side walls, field reversible glass doors, large swivel casters with wheel locks and 1829 mm (6') cord and plug are standard
- Perfect for serving counters, buffet lines, drive-up windows, point-of-service or preparation areas

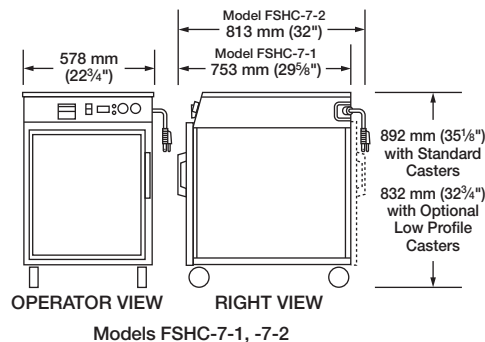

DIMENSIONS

Cabinet Opening: FSHC-7-1, -7-2 – 470 W x 559 H mm (18 1/2" x 22")
FSHC-6W1, -6W2 – 546 W x 483 H mm (21 1/2" x 19")

Top Surface: FSHC-7-1, -7-2 – 575 W x 657 D mm (22 5/8" x 25 7/8")
FSHC-6W1, -6W2 – 645 W x 657 D mm (25 3/8" x 25 7/8")

SPECIFICATIONS

Model	Type	Rack Style	Shipping Weight
FSHC-7-1	1 Door	Adjustable Angle Slides*	76 kg (168 lbs.)
FSHC-7-2 [▲]	2 Doors	Adjustable Angle Slides*	78 kg (172 lbs.)
FSHC-6W1	1 Door	Adjustable Angle Slides*	79 kg (175 lbs.)
FSHC-6W2 [▲]	2 Doors	Adjustable Angle Slides*	81 kg (179 lbs.)

* Seven slides on each side standard. Additional slides available. Sheet Pans not included.

[▲] FSHC-7-2 and FSHC-6W2 are each a two-door pass-through single cabinet, not two units stacked.

* Six slides on each side standard. Additional slides available. Sheet Pans not included.

VOLTAGE

FSHC-7-1, -7-2:
220 volts, 50 Hz, 1697 watts, 7.7 amps (CEE 7/7 Schuko).
240 volts, 50 Hz, 1697 watts, 7.1 amps (BS-1363 British).
120 volts, 60 Hz, 1697 watts, 14.1 amps (NEMA 5-15P, NEMA 5-20P – Canada).

FSHC-6W1, -6W2:
220 volts, 50 Hz, 1697 watts, 7.7 amps (CEE 7/7 Schuko).
240 volts, 50 Hz, 1697 watts, 7.1 amps (BS-1363 British).
120 volts, 60 Hz, 1697 watts, 14.1 amps (NEMA 5-15P, NEMA 5-20P – Canada).

CORD LOCATION

Back of unit, upper right side.

WATER TANK CAPACITY

3 liters (3/4 gallon).

WATER QUALITY REQUIREMENTS

See page 12 of this brochure for details.



Model FSHC-6W1 with accessory pans



Models FSHC-7-1/FSHC-7-1 with accessory stacking hardware and food pans

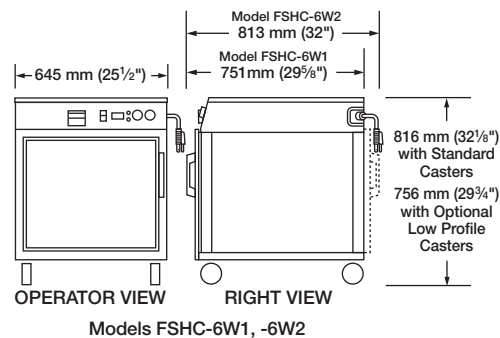

PORTABLE

**HUMIDIFIED
HOLDING & DISPLAY
CABINETS**

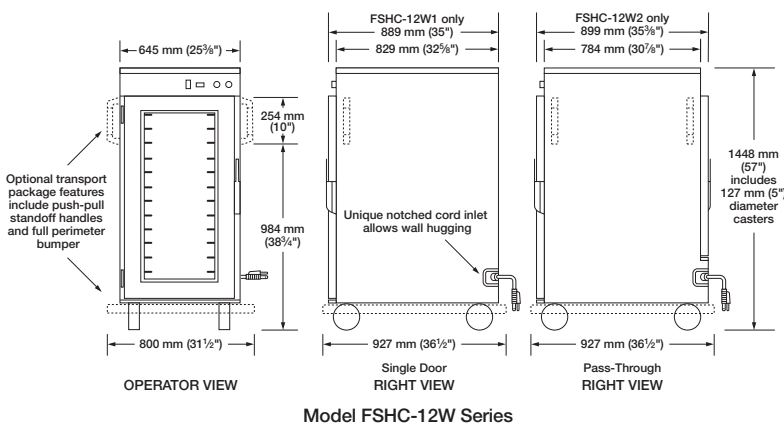

Model FSHC-12W Series



Model FSHC-12W1
with accessory food pans

**FLAV-R-SAVOR®
TALL HUMIDIFIED
HOLDING CABINETS**

People want lots of menu choices – yet often don't have time to wait for food to be prepared from start to finish at the time of order. Give your customers more menu choices and hold larger quantities of proven favorites ahead of peak serving periods with these Flav-R-Savor® Tall Humidified Holding Cabinets.

- Hold full sheet, Gastronorm, or steam table pans
- Two sizes to fit your kitchen's needs
- Models are available with pass-through design
- Dutch doors available on FSHC-17W models
- Temperatures from 32° – 82°C (90° – 180°F) will accommodate proofing

FSHC-12

FSHC-17



Model FSHC-17W1
with accessory food pans

DIMENSIONS

Cabinet Opening: FSHC-12W – 559 W x 1041 H mm (22" x 41").
FSHC-17W – 559 H x 1499 W mm (22" x 59").

SPECIFICATIONS

Model	Type*	Rack Style	Shipping Weight
FSHC-12W1	1 Door	Adjustable Angle Slides▲	120 kg (265 lbs.)
FSHC-12W2	2 Doors Pass-Through	Adjustable Angle Slides▲	134 kg (295 lbs.)
FSHC-17W1	1 Door	Adjustable Angle Slides*	134 kg (295 lbs.)
FSHC-17W1D	1 Opening 2 Dutch Doors	Adjustable Angle Slides*	138 kg (305 lbs.)
FSHC-17W2	2 Doors Pass-Through	Adjustable Angle Slides*	147 kg (325 lbs.)
FSHC-17W2D	4 Dutch Doors Pass-Through	Adjustable Angle Slides*	154 kg (340 lbs.)

* Full view Lexan® doors with full perimeter gaskets.

▲ 12 slides on each side standard. Additional slides available. Sheet Pans not included.

• 17 slides on each side standard. Additional slides available. Sheet Pans not included.

VOLTAGE

220 volts, 50 Hz, 1760 watts, 8.0 amps (CEE 7/7 Schuko).
240 volts, 50 Hz, 2095 watts, 8.7 amps (BS-1363 British).
120 volts, 60 Hz, 1750 watts, 14.6 amps (NEMA 5-15P, NEMA 5-20P – Canada).

CORD LOCATION

Facing controls, right-hand side panel, lower right corner. Cord length 3048 mm (10').

WATER TANK CAPACITY

8 liters (2 gallons).

WATER QUALITY REQUIREMENTS

See page 12 of this brochure for details.

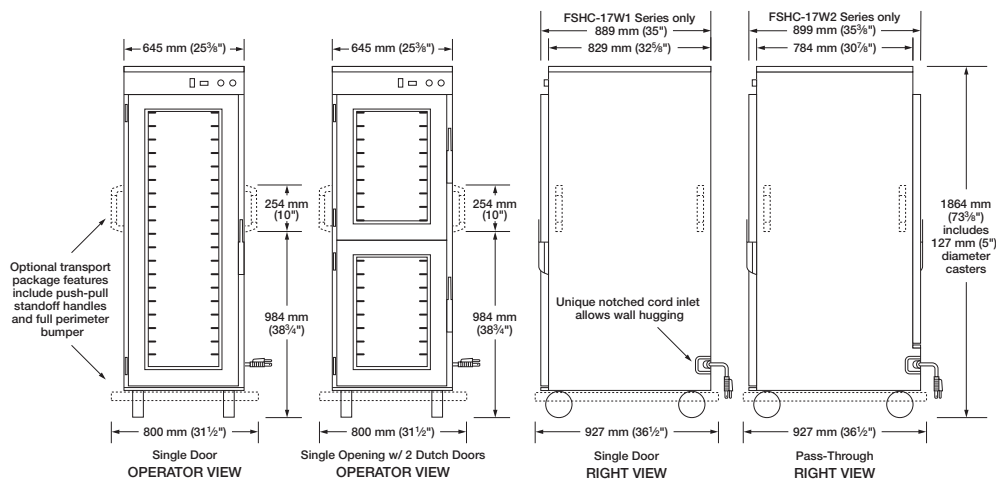

Model FSHC-17W Series



PLUG CONFIGURATIONS

Model	220 Volt 50/60 Hz	230 Volt 50 Hz	240 Volt 50/60 Hz	120 Volt 60 Hz	120/208 Volt 60 Hz	208 Volt 60 Hz
FSD/FSDT	CEE 7/7 Schuko	–	BS-1363	NEMA 5-15P	–	–
FDWDE	CEE 7/7 Schuko	–	BS-1363	NEMA 5-15P	–	–
FDWD	CEE 7/7 Schuko	–	BS-1363	NEMA 5-15P	–	–
MDW	CEE 7/7 Schuko	CEE 7/7 Schuko, BS-1363	BS-1363	NEMA 5-15P	–	–
WFST	CEE 7/7 Schuko	–	BS-1363	NEMA 5-15P*	NEMA L14-20P	–
MN	CEE 7/7 Schuko	–	BS-1363	NEMA 5-15P	–	–
FSHAC-2	CEE 7/7 Schuko	–	BS-1363	NEMA 5-20P	NEMA L14-20P	–
FSHAC-3	CEE 7/7 Schuko	–	BS-1363	–	NEMA L14-20P	–
FSHACH-2	CEE 7/7 Schuko	–	BS-1363	–	NEMA L14-20P	–
FS2HAC-2PT	CEE 7/7 Schuko	–	BS-1363	–	NEMA L14-30P	NEMA L6-20P
FS2HAC-4PT	CEE 7/7 Schuko	–	BS-1363	–	NEMA L14-30P	NEMA L6-20P
FSHC	CEE 7/7 Schuko	–	BS-1363	NEMA 5-15P*	–	–
PFST	CEE 7/7 Schuko	–	BS-1363	NEMA 5-15P*	–	–

Colored areas indicate models for export use only. * NEMA 5-20P for Canada

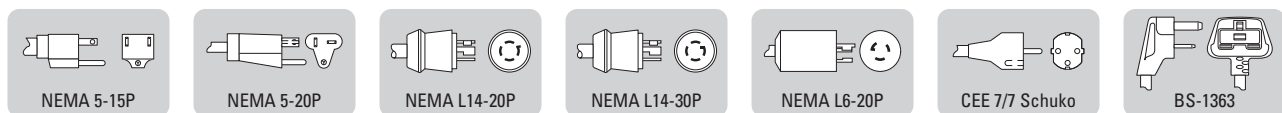

Unique Needs, Exact Solutions.

At Hatco we look, listen, and bring our full experience to your operation. "Customerization" is our brand promise...providing you with foodservice innovations that build your profits. That's Hatco, and that's always good for business.

Contact us today for all of your foodservice equipment needs.



"Nothing less than the best."

P.O. Box 340500
 Milwaukee, WI 53234-0500 USA
 (414) 671-6350
 www.hatcocorp.com
 E-mail: intlsales@hatcocorp.com

WATER QUALITY REQUIREMENTS

Water supply in excess of .75 grains of hardness per liter (GPL) (3.0 grains of hardness per gallon (GPG)) must be treated and softened before being used. Water containing over .75 GPL (3.0 GPG) will decrease the efficiency and reduce the operating life of the unit.

Note: Product failure caused by liming or sediment buildup is not covered under warranty.



Form No. HDCB-0712EXP-ENG
 July 2012