

WAREWASHING
UNDERCOUNTER DISHWASHER

HOBART

Ecomax 502L

EFFICIENT – RELIABLE – INNOVATIVE





WAREWASHING
UNDERCOUNTER DISHWASHER

Ecomax 502L

EFFICIENT – RELIABLE – INNOVATIVE

Mini Warewashing Specialist

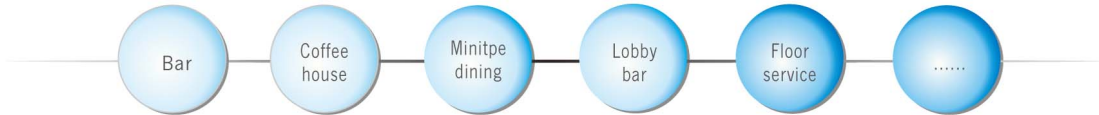

- ☆ 790mm height, the real undercounter dishwasher
- ☆ Set washing dishes and glasses all in one
- ☆ Suitable for below 100 seats

1 | Compact Size

- + Total 790mm in height, can be installed under the standard working table
- + High loading height of the wash chambers allow to cover bigger plates
- + Occupies a small area, saving area of dishwasher house
- + Built-in drain pump (option), provides installing flexibility
- + Built-in dispenser (option), using simply and saving space

2 | Ease for using

- + Soft touch button assures easy handing
- + Soft action considerably reduces the noise emission
- + Washing and rinse temperature indication, convenience for monitoring data

3 | Wash result

- + Roating upper and under washing system to distribute the ideal water uniformly over warewashers
- + Anti-clogging wide angle nozzle fan, provide a substantially broader and more precise spraying pattern, and outstanding washing efficiency
- + Thermostop feature guarantees 82°C final rinse
- + Two washing cycle selection
- + Automatic self cleaning

4 | Energy saving

- + Robust and durable double skin door, reduces heat emission
- + Interlock feature lowers the electric loading
- + SST housing and rinse arm assures easy for cleaning, apply to HACCP standard





Ecomax 502L

EFFICIENT – RELIABLE – INNOVATIVE



Soft action closing, saving power



Soft touch, operation simply



Rotating wash and rinse arms



Front strainer, cleaning easily

5 | Technical Data

Parameters		Unit	Ecomax 502L		
Wash capacity		Racks/h	60	30	30
Inlet water temperature		°C	45-65	10-65	58-65
Voltage ⁽¹⁾		V/Hz/Ph	380/50/3		220/50/1
Total loading	Non-interlock	kW	9.6 / 21		4.6 / 21
	Interlock ⁽²⁾	kW	7.9 / 13		2.9 / 13
Booster heating		kW	7.5		2.5
Tank heating		kW	1.7		
Wash pump		kW	0.37		
Wash temperature		°C	55-60		
Rinse temperature		°C	82-90		
Water consumption		L/rack	3		
Tank volume		L	18		
Inlet water pressure		bar	0.5-6		
Rack size		mm	500×500		
Loading height		mm	315		
Dimensions(WxDxH)		mm	575×600×790		

Standard	Rinse pump
Option	Drain pump
	Dispensers

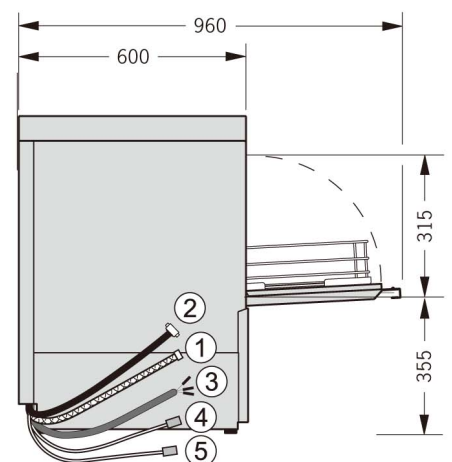
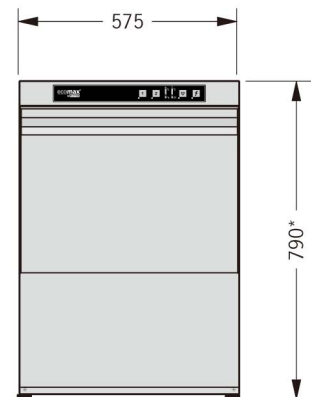

- (1) Optional electricity 60Hz.
 (2) Interlock option for 380/50/3, but wash temperature will lower 5.5 °C .
 (Interlock function --- tank heating and booster heating don't work at the same time.)

- ① Drain hose (2m, DN25 inner, DN25 outer)
 ② Fresh water hose (2m, G3/4", 17L/min, 10-65 °C)
 ③ Power core (2m, 4mm², 380/50/3-phase 5-line)
 ④ Detergent hose (option)
 ⑤ Rinse aid hose (option)
 * = +30mm adjustable feet



For more information contact Hobart or your local Hobart dealer

ITW FEG (HK) Ltd
HongKong
Tel: 852-2341 9315
www.hobart.com.hk

Hobart International (Singapore) Pte Ltd
Singapore
Tel: 65-6846 7117
www.hobart.com.sg

Hobart Food Equipment
Sydney, Australia
Tel: 61-2-9714 0200
www.hobartfood.com.au

Hobart Food Equipment Co., Ltd
Tianjin, China
Tel: 86-22-2397 4914
www.hobartchina.com

Hobart (Japan) K.K.
Tokyo, Japan
Tel: 813-3744 3511
www.hobart.co.jp

Hobart Korea LLC
Seoul, Korea
Tel: 822-3443 6901
www.hobart.co.kr

Hobart (Thailand)
Bangkok, Thailand
Tel: 66-2-675 6279
www.hobartthailand.com



Warewashing



Food Preparation



Refrigeration



Baking



Cooking



Waste Management



Service