



# Sneeze Guard Solutions

*Cafeterias • Convenience Stores  
Supermarkets & Delis • Restaurants & Cafés  
Clubs & Bars • Catering • Concessions*



SGPT-30 pg. 2



SGCP-48 pg. 2



SGEN-40 pg. 2



# Sneeze Guard Solutions

## Sneeze Guards

Simultaneously enhance and protect food products with Hatco Sneeze Guards. These stylish, functional Sneeze Guards are ideal for buffet lines, serving stations and temporary service areas in safeguarding your foods.

- Available as Portable, Counter Post or Enclosed
- Stylish brushed aluminum posts with clear finish are easy to clean
- Radiused corners, tempered safety glass with penciled edges provides clean look
- Ability to change glass angle (360° adjustment) to fit with your foodservice equipment (SGCP, SGPT models only)
- NSF approved
- Assembly required

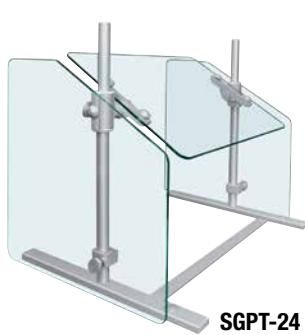

SGPT-24



SGCP-48



SGEN-40

### PORTABLE SNEEZE GUARDS

Model	Exterior Dimensions W* x D x H	Usable Interior Space W x D x H	Ship Weight
SGPT-24	24" x 20 <sup>3</sup> / <sub>8</sub> " x 22"	20 <sup>1</sup> / <sub>8</sub> " x 18" x 13 <sup>1</sup> / <sub>2</sub> "	152 lbs.
SGPT-30	30" x 20 <sup>3</sup> / <sub>8</sub> " x 22"	26 <sup>1</sup> / <sub>8</sub> " x 18" x 13 <sup>1</sup> / <sub>2</sub> "	183 lbs.
SGPT-36	36" x 20 <sup>3</sup> / <sub>8</sub> " x 22"	32 <sup>1</sup> / <sub>8</sub> " x 18" x 13 <sup>1</sup> / <sub>2</sub> "	213 lbs.
SGPT-42	42" x 20 <sup>3</sup> / <sub>8</sub> " x 22"	38 <sup>1</sup> / <sub>8</sub> " x 18" x 13 <sup>1</sup> / <sub>2</sub> "	244 lbs.
SGPT-48	48" x 20 <sup>3</sup> / <sub>8</sub> " x 22"	44 <sup>1</sup> / <sub>8</sub> " x 18" x 13 <sup>1</sup> / <sub>2</sub> "	264 lbs.
SGPT-54	54" x 20 <sup>3</sup> / <sub>8</sub> " x 22"	50 <sup>1</sup> / <sub>8</sub> " x 18" x 13 <sup>1</sup> / <sub>2</sub> "	305 lbs.
SGPT-60	60" x 20 <sup>3</sup> / <sub>8</sub> " x 22"	56 <sup>1</sup> / <sub>8</sub> " x 18" x 13 <sup>1</sup> / <sub>2</sub> "	335 lbs.

\*Add 1.375" to width for knobs.

### COUNTER POST SNEEZE GUARDS

Model	Exterior Dimensions W x D x H	Usable Interior Space W x D x H	Ship Weight
SGCP-24	24 <sup>3</sup> / <sub>4</sub> " x 18" x 22"	18 <sup>1</sup> / <sub>2</sub> " x 18" x 13 <sup>1</sup> / <sub>2</sub> "	152 lbs.
SGCP-30	30 <sup>3</sup> / <sub>4</sub> " x 18" x 22"	24 <sup>1</sup> / <sub>2</sub> " x 18" x 13 <sup>1</sup> / <sub>2</sub> "	183 lbs.
SGCP-36	36 <sup>3</sup> / <sub>4</sub> " x 18" x 22"	30 <sup>1</sup> / <sub>2</sub> " x 18" x 13 <sup>1</sup> / <sub>2</sub> "	213 lbs.
SGCP-42	42 <sup>3</sup> / <sub>4</sub> " x 18" x 22"	36 <sup>1</sup> / <sub>2</sub> " x 18" x 13 <sup>1</sup> / <sub>2</sub> "	244 lbs.
SGCP-48	48 <sup>3</sup> / <sub>4</sub> " x 18" x 22"	42 <sup>1</sup> / <sub>2</sub> " x 18" x 13 <sup>1</sup> / <sub>2</sub> "	264 lbs.
SGCP-54	54 <sup>3</sup> / <sub>4</sub> " x 18" x 22"	48 <sup>1</sup> / <sub>2</sub> " x 18" x 13 <sup>1</sup> / <sub>2</sub> "	305 lbs.
SGCP-60	60 <sup>3</sup> / <sub>4</sub> " x 18" x 22"	54 <sup>1</sup> / <sub>2</sub> " x 18" x 13 <sup>1</sup> / <sub>2</sub> "	335 lbs.

### ENCLOSED SNEEZE GUARDS

Model	Exterior Dimensions W x D x H	Usable Interior Space W x D x H	Ship Weight
SGEN-22	22 <sup>5</sup> / <sub>8</sub> " x 19 <sup>3</sup> / <sub>8</sub> " x 19"	16 <sup>3</sup> / <sub>8</sub> " x 17 <sup>3</sup> / <sub>8</sub> " x 17 <sup>3</sup> / <sub>4</sub> "	142 lbs.
SGEN-28	28 <sup>5</sup> / <sub>8</sub> " x 19 <sup>3</sup> / <sub>8</sub> " x 19"	22 <sup>3</sup> / <sub>8</sub> " x 17 <sup>3</sup> / <sub>8</sub> " x 17 <sup>3</sup> / <sub>4</sub> "	173 lbs.
SGEN-34	34 <sup>5</sup> / <sub>8</sub> " x 19 <sup>3</sup> / <sub>8</sub> " x 19"	28 <sup>3</sup> / <sub>8</sub> " x 17 <sup>3</sup> / <sub>8</sub> " x 17 <sup>3</sup> / <sub>4</sub> "	203 lbs.
SGEN-40	40 <sup>5</sup> / <sub>8</sub> " x 19 <sup>3</sup> / <sub>8</sub> " x 19"	34 <sup>3</sup> / <sub>8</sub> " x 17 <sup>3</sup> / <sub>8</sub> " x 17 <sup>3</sup> / <sub>4</sub> "	234 lbs.
SGEN-46	46 <sup>5</sup> / <sub>8</sub> " x 19 <sup>3</sup> / <sub>8</sub> " x 19"	40 <sup>3</sup> / <sub>8</sub> " x 17 <sup>3</sup> / <sub>8</sub> " x 17 <sup>3</sup> / <sub>4</sub> "	264 lbs.
SGEN-52	52 <sup>5</sup> / <sub>8</sub> " x 19 <sup>3</sup> / <sub>8</sub> " x 19"	46 <sup>3</sup> / <sub>8</sub> " x 17 <sup>3</sup> / <sub>8</sub> " x 17 <sup>3</sup> / <sub>4</sub> "	295 lbs.
SGEN-58	58 <sup>5</sup> / <sub>8</sub> " x 19 <sup>3</sup> / <sub>8</sub> " x 19"	52 <sup>3</sup> / <sub>8</sub> " x 17 <sup>3</sup> / <sub>8</sub> " x 17 <sup>3</sup> / <sub>4</sub> "	325 lbs.

**SGXX-XX**

Sneeze Guard \_\_\_\_\_

PT = Portable

CP = Counter Post

EN = Enclosed

Width in inches



Scan with web-enabled  
mobile device to visit  
[www.hatcocorp.com](http://www.hatcocorp.com)



Hatco Corporation

P.O. Box 340500 | Milwaukee WI 53234-0500 USA  
800-558-0607 | 414-671-6350 | Fax: 800-543-7521  
[www.hatcocorp.com](http://www.hatcocorp.com) | [equipsales@hatcocorp.com](mailto:equipsales@hatcocorp.com)